

### 内置气弹簧

- 气压手臂可以上下调节高度，可左右推拉，灵活轻巧；
- 线缆可以掩盖在手臂下方；
- 符合国际VESA标准，并具有快速装卸。

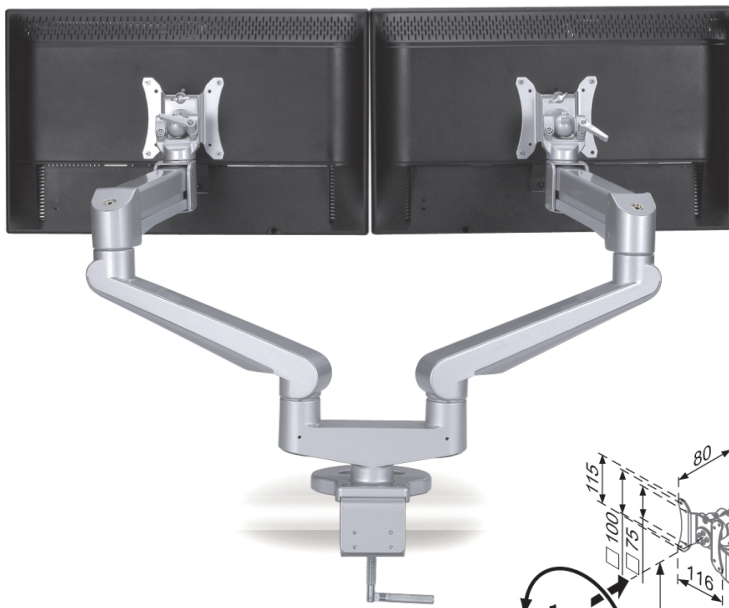

快速装卸

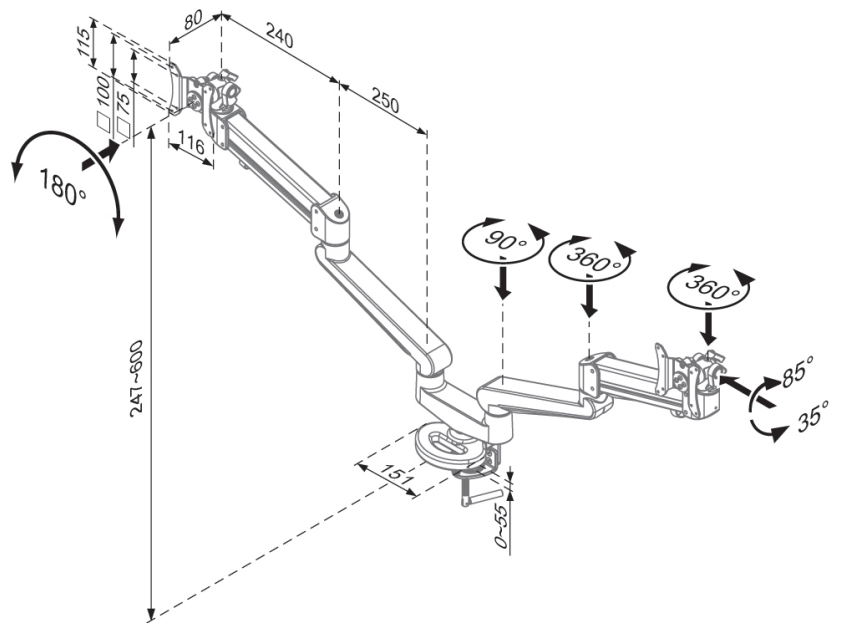

夹具、锁孔

unit:mm

EA-215

 承重: 8-19kg

 75X75&100X100mm



公司官网



公众号



产品参数